



SPECIFICATION

1. DESCRIPTION

The DK124 IC is specially design for off-line switch mode power supply, maximum power is 24W. Different from PWM controller and external power separated MOS combination design, the PWM controller, 700V power transistor, and high voltage starting circuit are integrated into his DK124 IC. So that to save external circuit, component use and cost. Also size and weight of the product is reduced. It is specially suitable for price sensitive flyback switch mode power supply.

2. APPLICATIONS

- Battery charger
- Power AC/DC adapters
- STB power supply
- Electromagnetic oven power supply
- DVD/VCD/VCR power supply
- Air conditioner power supply
- LED driver applications
- TV/Monitor power supply

3. MAIN FEATURES

- 85V—265V wide range AC power input.
- Build-in 700V power transistor.
- Internal integrated high voltage starting circuit, no need for additional resistance.
- Internal 16mS soft-start circuit.
- Internal power compensation circuit to keep the stability of max. output power in both high and low voltage.
- Patent dynamic self-power supply, no need for auxiliary winding.
- Internal frequency modulation circuit to reduce EMI filter cost.
- Over current, Over loading, Over temperature, Over voltage and Short circuit Protection.

4. POWER RANGE

Input Voltage	85-264V AC	85-145V AC	180-264V AC
MAX. output power	12W	18W	18W

5. CONNECTION DIAGRAM (DIP-8)

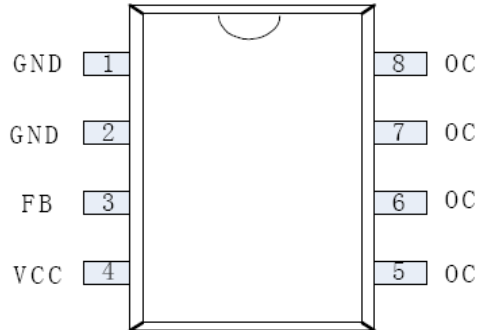
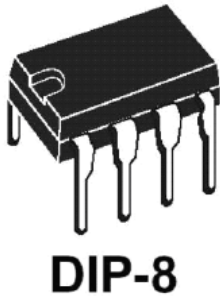

PIN FUNCTION

Pin NO.	Pin Name	Function
1	GND	Ground reference of IC
2	GND	Ground reference of IC
3	Fb	Feedback control pin
4	Vcc	IC Power supply
5,6,7,8	OC	Output pin of power transistor

6. BLOCK DIAGRAM

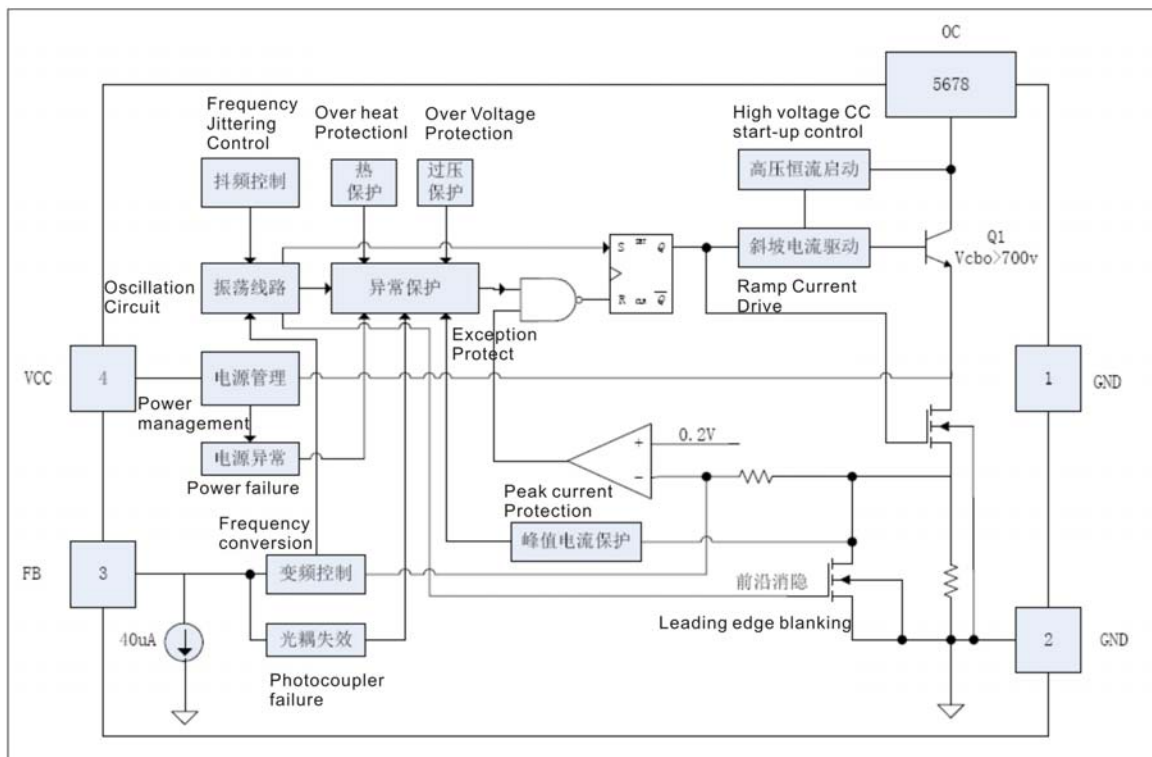

7. ABSOLUTE MAXIMUM RATINGS

Symbol	Parameter	Value	Unit
Vcc	Supply voltage	-0.3V--8	V
Ivcc	Current of supply voltage	100	mA
Vpin	Pin voltage	-0.3--Vcc+0.3	V
Vcol	Collector to GND voltage	-0.3--780	V
Ip	Peak current	1.5	A
Pd	Dissipation power	1	W
Tc	Case operating temperature	-20--+140	°C
Tstg	Storage temperature	-55--+150	°C
Tsol	Soldering temperature	+280	°C/5S

8. ELECTRICAL CHARACTERISTIC

Parameter	Condition	Value			Unit
		Min.	Typ.	Max.	
Vcc (Work Power Supply)	AC input: 85V-265V	4.65	4.95	5.25	V
Start threshold Voltage	AC input: 85V-265V	4.75	5.05	5.35	V
Restart Voltage	AC input: 85V-265V	3.3	3.6	3.9	V
Protect Voltage of VCC	AC input: 85V-265V	6.25	6.55	6.85	V
Current of Vcc	Vcc=5V, Fb=1.5V			50	mA
High voltage start current	AC input: 85V-265V	0.3	0.6	1.2	mA
Start time	AC input: 85V	--	--	500	mS
BJT Voc Breakdown voltage	Ioc=1mA	700	--	--	V
Collector Protection Voltage	Check OC voltage	540	600	660	V
Peak Current Protection	Vcc=5V, Fb=1.5V---2.8V	1100	1300	1500	mA
PWM Output frequency	Vcc=5V, Fb=1.5V---2.5V	61	65	69	Khz
	Vcc=5V, Fb=2.5V---2.8V	20	22	24	Khz
Stepped Frequency	Vcc=5V, Fb=1.5V---2.5V		0.5		Khz
Short circuit protection threshold	Tested FB voltage	1.15	1.33	1.50	V
frequency conversion threshold voltage	Tested FB voltage	2.3	2.7	2.7	V
Burst mode threshold	Tested FB voltage	2.6	2.8	3.0	V
Temperature protection	junction temperature	120	130	140	°C
Leading edge blanking time	Vcc=5V, Fb=1.5V---2.5V		250		nS
Min. turn-on time	Vcc=5V, Fb=2.6V		500		nS
Duty cycle of PWM	Vcc=5V, Fb=1.5V---2.5V	5	--	70	%
Standby power loss	AC input: 265V, unloaded		240		mW

9. OPERATION PRINCIPLE

9.1 Start Up

When power on, external VCC capacitor is charged by internal high voltage constant current coming for internal connected OC and VCC pins. When V_{CC} voltage comes up to 5V, starting up finishes, the circuit enters into normal working mode and outputs PWM.

9.2 Soft-start

As to protect the transistor and secondary commutator tube, there is a 16 mS soft start-up circuit in the IC. In the 16mS, the PWM starting up time is increased step by step, so that the peak current of resistor increased linearly from 100mA to peak current.

9.3 Feedback Control

9.4 Standby burst mode

9.5 Self-Power Supply Circuit (National patent owned)

There is self-power supply circuit inside the IC, which can control the power voltage about 5V for the electricity consumption of the IC itself. It can only afford the electricity consumption of itself only but can not afford for the external circuit.

9.6 Frequency Jittering Circuit

By sweeping the switching frequency around its nominal value 65KHz, it spreads the energy content on adjacent frequencies rather than keeping it centered in one single ray. This offers the benefit to artificially reduce the measurement noise on a standard EMI/EMC receiver and pass the tests more easily.

9.7 Over Temperature Protection (OTP)

When the controller detects the device temperature exceeds 130°C, OTP is activated. It stops the switching operation immediately and enters into the stop status. The controller will restart to switching operation when the temperature falls down.

9.8 Over Current Protection (OCP)

Whenever the collector current (I_p) abnormally exceeds the maximum current limit of 1.3A, the controller would stop operation and enters into stop status.

9.9 Abnormal Voltage Protection

Whenever the power voltage (V_{cc}) abnormally exceeds 6.5V and drops under 3.6V, the controller would stop operation and enters into stop status until the voltage comes back to normal.

9.10 Over Collector Voltage Protection

Whenever the voltage of the collector pin exceeds the limit of 600V, the controller will decrease the power output to make sure the collector pin coming back to normal. It could reduce the stress of the power transistor and the protect power transistor from avalanche damage.

9.11 Constant Power Control

9.12 Short Circuit and Over Load Protection

10. TYPICAL APPLICATION SAMPLE

(12V2A OUTPUT FLYBACK TYPE SWITCH MODE POWER SUPPLY)

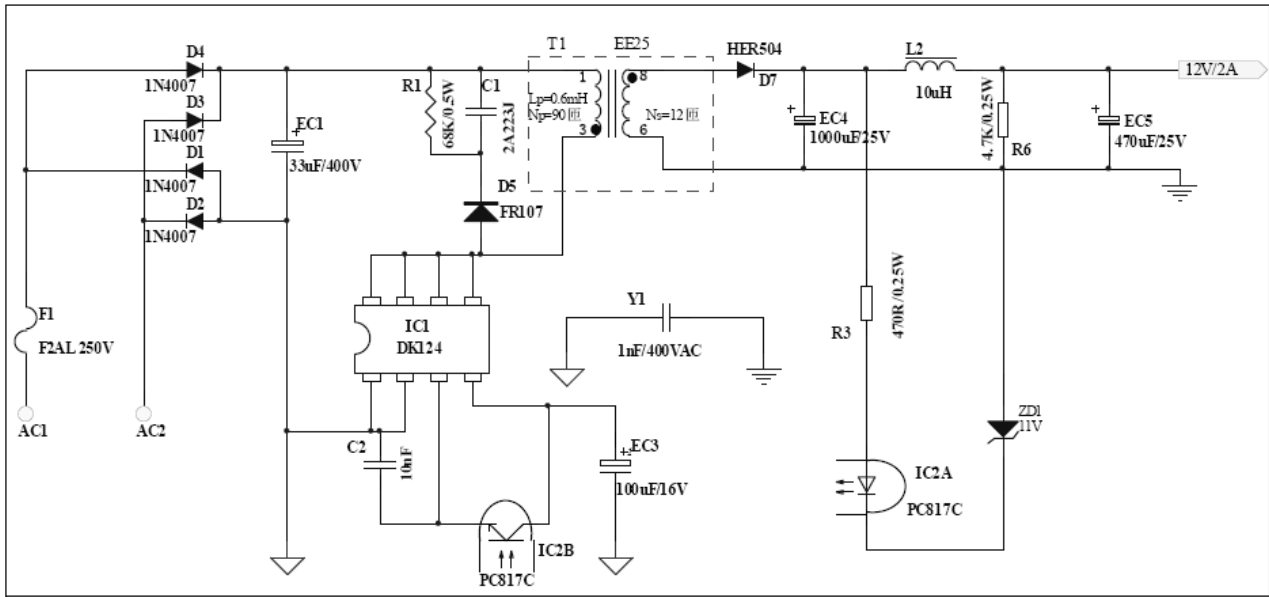

10.1 Components list

NO.	NAME	SPEC. / MODEL NO.	POSITION	USED QTY	REMARK
1	Fuse	F2A/AC250V	F1	1	
2	Diode	IN4007	D1~D4	4	
3	Diode	FR107	D5	1	
4	Diode	HER504	D7	1	
5	Electrolytic capacitor	100uF/16V	EC3	1	
6	Electrolytic capacitor	1000uF/25V	EC4	1	
7	Electrolytic capacitor	470uF/25V	EC5	1	
8	Electrolytic capacitor	33uF/400V	EC1	1	
9	Dacron Capacitor	2A223J	C1	1	
10	Ceramic capacitor	10nF	C2	1	
11	Y capacitor	1nF/400V	Y1	1	
12	Resistance	68K/0.5W	R1	1	
13	Resistance	470R	R3	1	
14	Resistance	4.7K	R6	1	
15	Zener Diode	11V	ZD1	1	
16	I-shape inductance	10uH	L2	1	
17	IC	DK124	IC1	1	



18	Photo-coupler	PC817	IC2	1	
19	Transformer	EE25	T1	1	

12.1 Heat dissipation: A good estimate is that the controller will dissipate the output power. So enough cooper area connected to the 5, 6, 7, 8 COLLECTED pins and tin-plating are necessary to provide the controller heat sink.

12.2 The 5, 6, 7, 8 COLLECTED pins is high voltage part of the IC, peak voltage is as high as 600V, so it should be at least 1.5mm far away from the low voltage part in the PCB as to avoid circuit breakdown and discharging.

12.3 Pin No.1 is for testing only. It is prohibited to be connected with other circuits when in use.

11. TRANSFORMER DESIGN (For reference only)

11.1 Parameter confirmation: confirm the below parameter before transformer design

- (1) Input voltage range (for example :AC85V-265V)
- (2) Output Voltage and current (for example DC12V 2A)

11.2 Core selecting

- (1) Input power calculation

Pi=Pout/η (η is the efficiency of the power supply, take it 0.8 for example), Pout=Vout*Iout=12V*2A=24W, Pi=24/0.8=30W.

- (2) Choose the core:

Checking via supplier or the correlative chart can know that EE25 or EE19 core is suitable for 30W power supply. Now we choose EE16 for below calculation.

11.3 Input inductance value (Lp)

$$L_p = \frac{2 * P_i}{I_p * I_p * F_s} = \frac{2 * 30W}{1.32A * 1.32A * 65k} \approx 0.53mH$$

PS: Ip---Input peak current (it is set to be 1320mA in the IC)

11.4 Number of the original(input) turns (Np)

$$N_p = \frac{L_p * I_p \max}{\Delta B * A_e} = \frac{0.53 * 1.32}{0.2 * 0.04} \approx 90$$

PS: Δ B---Alternating working magnetic flux density (mT), set to be 0.2

Ae-----Core effective area (m m²), EE25/19's Ae is 40 m m²

11.5 Number of the output turns (Ns)

$$N_s = (V_{out} * N_p) / V_{or} = (13 * 90) / 80 \approx 15$$

PS: Vout---Output voltage=12V+1V=13V, take the voltage loss (from wires and rectification) into consideration.

Vor-----Flyback voltage=80V, set it lower then 150V for the safety of IC.

12. SPECIAL NOTICE FOR PBC LAYOUT DESIGN

12.1 Heat dissipation: A good estimate is that the controller will dissipate the output power. The main heating comes from power transistor that connected with Pin 7 & 8 of the IC. So enough cooper area connected to pin 7

& 8 and tin-plating are necessary to provide the controller heat sink.

12.2 The 7, 8 COLLECTED pins is high voltage part of the IC, peak voltage is as high as 600V, so it should be at least 1.5mm far away from the low voltage part in the PCB as to avoid circuit breakdown and discharging.

12.3 It is suggested to use P/S/P way to wind the transformer so that to reduce the leakage inductance.

13. MECHANICAL AND PACKING INFORMATION

Symbol	Dimensions In Millimeters		Dimensions In Inches	
	Min	Max	Min	Max
A	3.710	4.310	0.146	0.170
A1	0.510		0.020	
A2	3.200	3.600	0.126	0.142
B	0.380	0.570	0.015	0.022
B1	1.524 (BSC)		0.060 (BSC)	
C	0.204	0.360	0.008	0.014
D	9.000	9.400	0.354	0.370
E	6.200	6.600	0.244	0.260
E1	7.320	7.920	0.288	0.312
e	2.540 (BSC)		0.100 (BSC)	
L	3.000	3.600	0.118	0.142
E2	8.400	9.000	0.331	0.354

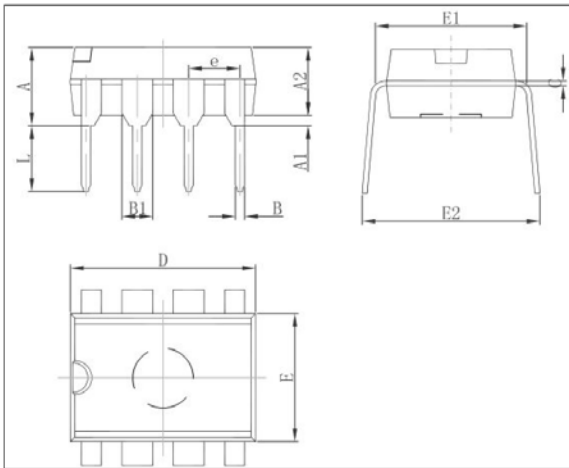

• Packing quantity

QTY/tube	QTY/inner carton	QTY/master carton
50	2000	20000